

# Product datasheet

Folding door

Crawford FD2050P

**ASSA ABLOY**

ASSA ABLOY Entrance Systems

The global leader in  
door opening solutions



# Copyright and Disclaimer Notice

Although the contents of this publication have been compiled with the greatest possible care, ASSA ABLOY Entrance Systems cannot accept liability for any damage that might arise from errors or omissions in this publication. We also reserve the right to make appropriate technical modifications/replacements without prior notice.

No rights can be derived from the contents of this document.

Color guides: Color differences may occur due to different printing and publication methods.

ASSA ABLOY, Besam, Crawford, Megadoor and Albany, as words and logos, are examples of trademarks owned by ASSA ABLOY Entrance Systems or companies within the ASSA ABLOY Group.

Copyright © ASSA ABLOY Entrance Systems AB 2006-2014.

No part of this publication may be copied or published by means of scanning, printing, photocopying, microfilm or any other process whatsoever without prior permission in writing by ASSA ABLOY Entrance Systems.

All rights reserved.

# Technical facts

## Features

|                          |  |
|--------------------------|--|
| Max size: (W x H)*       | 7590 mm x 6000 mm  |
| Leaf thickness:          | 50 mm  |
| Material:                | CFC-free polyurethane with sheet metal inner and outer skins   |
| Colour outside / inside: | Standard 5 pre-coated colours  |
| Windows:                 | TG1, TG2, TG5  |
| Passdoor:                | Optional: built in door leaf, built in fixed section, leaf as passdoor   |
| Electrical operation:    | Manual operation,<br>Electrical operation                      Automated operation, Access control, Safety functions |

\* Other sizes are available on request

## Performance

|                                   |  |
|-----------------------------------|--|
| Life time expectations:           | Door: 300.000 door cycles/20 years (with the recommended yearly service check) |
| Wind load,<br>EN12424             | Manual operated door: Class 3<br>Electrical operated door: Class 5             |
| Thermal transmittance,<br>EN12428 | 1,7 W/m <sup>2</sup> .k ***  |
| Water penetration,<br>EN12425     | Class 3  |
| Air permeability,<br>EN12426      | Class 2  |

\*\* Up to DLW 3500 mm x DLH 3000

\*\*\* Door configuration 4000 mm x 4000 mm, 2 + 2

# Contents

|   |           |
|---|-----------|
| Copyright and Disclaimer Notice .....                                     | 2         |
| Technical facts .....   | 3         |
| Contents .....  | 4         |
| <b>1. Description .....</b>   | <b>6</b>  |
| 1.1 General.....  | 6         |
| 1.1.1 Standard.....   | 6         |
| 1.1.2 Options.....  | 6         |
| 1.2 Door leaves.....  | 7         |
| 1.2.1 Construction .....  | 7         |
| 1.2.2 Material .....  | 7         |
| 1.2.3 Colours .....   | 7         |
| 1.2.4 Seals.....  | 8         |
| 1.2.5 Windows.....  | 9         |
| 1.2.6 Passdoor.....   | 10        |
| 1.2.7 Fixed sections.....   | 10        |
| 1.3 Manually operated door .....  | 11        |
| 1.3.1 Handle .....  | 11        |
| 1.3.2 Locks.....  | 11        |
| 1.4 Electrically operated door .....                                      | 12        |
| 1.4.1 Electrical operation.....   | 12        |
| 1.4.2 CDM9 FD Operating system .....                                      | 12        |
| 1.5 Access and automation.....  | 12        |
| 1.5.1 Basic control functions .....                                       | 13        |
| 1.5.2 External control functions.....                                     | 13        |
| 1.5.3 Automatic control functions.....                                    | 13        |
| 1.5.4 Safety functions.....   | 14        |
| 1.5.5 Additional functions.....   | 14        |
| 1.6 Monitoring systems.....   | 15        |
| 1.6.1 Saving energy.....  | 15        |
| 1.6.2 Security enhancement .....  | 15        |
| 1.6.3 Dock management .....   | 15        |
| 1.6.4 Facility management .....   | 15        |
| <b>2. Specifications .....</b>  | <b>16</b> |
| 2.1 Dimensions.....   | 16        |
| 2.1.1 Daylight width and daylight height.....                             | 16        |
| 2.1.2 Section sizes .....   | 16        |
| 2.2 Configurations.....   | 17        |
| 2.3 Passdoor.....   | 18        |
| 2.3.1 Passdoor in doorleaf.....   | 18        |
| 2.3.2 Doorleaf as a passdoor .....  | 19        |
| 2.4 Door operation .....  | 19        |
| 2.4.1 Selection guidelines for operation type.....                        | 19        |
| 2.4.2 950 door control system functions .....                             | 20        |
| 2.4.3 950 door control system - Selection guidelines for automation ..... | 20        |

|       |   |    |
|-------|---|----|
| 3.    | CEN Performance .....                               | 22 |
| 3.1   | Lifetime expectation .....                          | 22 |
| 3.2   | Resistance to windload .....                        | 22 |
| 3.3   | Resistance to water penetration.....                | 22 |
| 3.4   | Air permeability .....                              | 22 |
| 3.5   | Thermal transmittance.....                          | 22 |
| 3.6   | Operating forces and safe openings.....             | 22 |
| 4.    | Building and space requirements .....               | 23 |
| 4.1   | Building preparations .....                         | 23 |
| 4.1.1 | Installation preparations.....                      | 23 |
| 4.1.2 | Electrical preparations .....                       | 23 |
| 4.2   | Space requirements .....                            | 24 |
| 4.2.1 | Dimension terminology .....                         | 24 |
| 4.2.2 | Space requirements manual doors.....                | 24 |
| 4.2.3 | Space requirements electrically operated doors..... | 25 |
| 4.2.4 | Depth .....   | 25 |
| 5.    | Service .....                                       | 26 |
|       | Index .....   | 27 |

# 1. Description

## 1.1 General

The Crawford FD2050P folding door is one of the most stable folding doors on the market. It is a well insulated folding door especially developed for demanding industrial environments. High flexibility makes it possible to install this door in almost every type of building. The door slides (folds) to the left, right, or in both directions if it is in two parts, leaving the door opening completely free. The door is made of aluminum tubular profiles, profiled steel sheets and injection moulded foam to make a stable sandwich construction. The door can be installed on either the inside or the outside of the exterior wall. A wide range of options is available to suit the appearance of the existing building.

The Crawford FD2050P folding door has been designed to meet all operational and safety requirements in the European Directives and the standards issued by the European Standardization Committee, CEN.

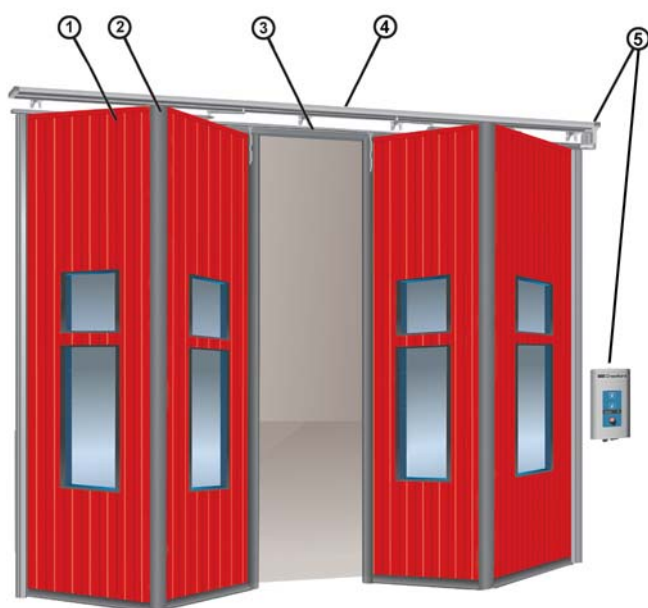

The Crawford FD2050P folding door has 5 primary parts:

- 1) Door leaf
- 2) Seals
- 3) Track
- 4) Transmission system (electrically operated door)
- 5) Operating system (electrically operated door)

### 1.1.1 Standard

Although every Crawford door is custom built, the Crawford FD2050P folding door is supplied with the following specifications as standard:

|                        |   |
|------------------------|---|
| Door leaf:             | Aluminium frames covered with steel sheets and filled with polyurethane insulation. |
| Operation:             | Manual: Auto lock in open position<br>Electrical: 950 door control system           |
| Locks:                 | Cremone lock inside (manual operation)  |
| Colours:               | 5 pre-coated colours  |
| Number of door leaves: | Max. 3 door leaves per side.  |
| Safety:                | Side cover  |

### 1.1.2 Options

Crawford provides a wide range of options and accessories to customise the Crawford FD2050P folding door to any customer's needs.

|            |   |
|------------|---|
| Passdoor:  | Built in door leaf<br>Built in fixed section<br>Entire leaf as passdoor                       |
| Windows:   | TG1, TG2, TG5: Double sided insulated hardened glass  |
| Locks:     | Assa lock box<br>Euro lock box<br>Kaba lock box<br>Abloy lock box                             |
| Painting:  | Factory painting any colour on request  |
| Operation: | Delivered with or prepared for:<br>Key locks system<br>Automated operation, safety functions. |

## 1.2 Door leaves

### 1.2.1 Construction

The Crawford FD2050P folding door comprises vertical door leaves, connected together with hinges. Rollers are installed on the top left and right of each door leaf. The rollers run in the top track to enable opening and closing of the door.

### 1.2.2 Material

The sections are made of aluminium profiles, clad with sheet metal panels, insulated with polyurethane foam.

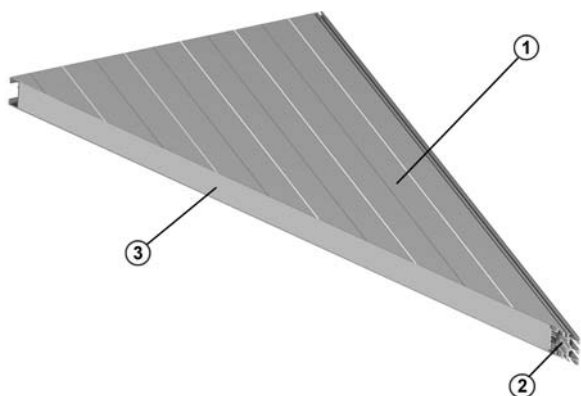

- 1) Rilled steel sheet
- 2) Aluminium frame
- 3) Polyurethane insulation

### 1.2.3 Colours

The Crawford FD2050P folding door is available in any colour on request.

#### 1.2.3.1 Standard colours

As a standard, the Crawford FD2050P folding door is available in 5 pre-coated colours.



#### 1.2.3.2 Optional colours

- Factory painting, all RAL colours, including metallic colours
- Factory painting, acc. to colour sample

### 1.2.4 Seals

The door is equipped with well designed seals on all sides that gives the door its excellent sealing abilities.

#### 1.2.4.1 Top seal

Installed on the frame at the top of the wall, the top seal provides continuous pressure on the top of the door leaves when the door is closed, ensuring maximum sealing.

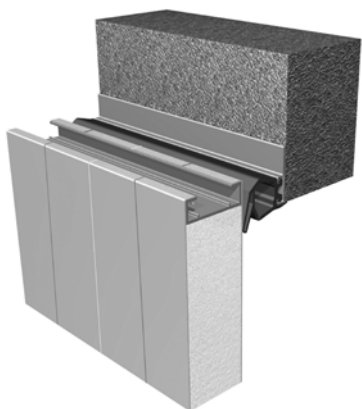

#### 1.2.4.2 Bottom seal

Installed on the bottom edge of each door leaf, the bottom seal provides continuous pressure on the floor, ensuring maximum sealing.



#### 1.2.4.3 Seal between hinged leaves

Installed between each pair of door leaves. The flexible rubber material permits maximum movement of the door assembly and permanent sealing between the door leaves.

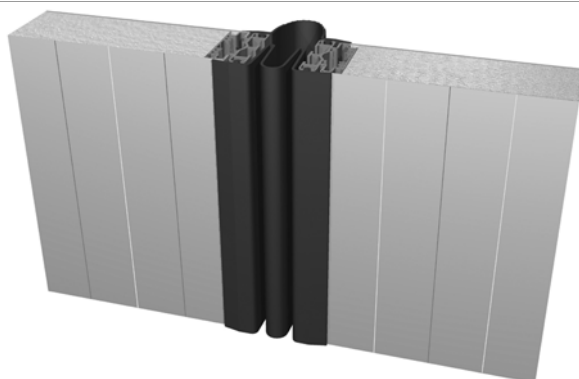

#### 1.2.4.4 Side seal

Installed between the outer door leaves and the wall. The flexible rubber material permits maximum movement of the door assembly and provides permanent sealing between the door leaves and the walls.

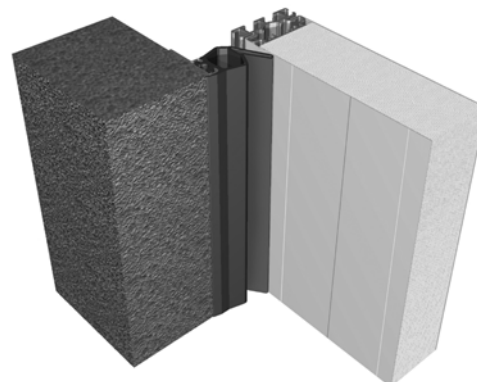

#### 1.2.4.5 Safety edge seal

Installed on the edge of the two centre door leaves, the safety edge seal provides continuous pressure when the door is closed, ensuring maximum sealing. On electrical doors the sealing has a function as safety edge sealing.



#### 1.2.4.6 Side cover

In combination with an installation frame the side cover works as a cover of and a protection from the frame hinges. Standard on all doors.

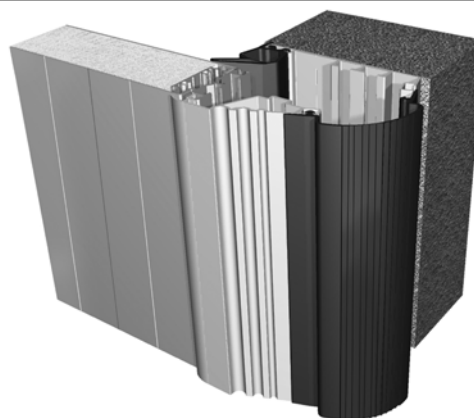



## 1.2.5 Windows

The frame construction allows windows in all door leaves. The light opening depends on the dimensions of the door leaf. Other materials than described below are available on request.

### 1.2.5.1 TG1



- Double-sided insulated hardened glass, rectangular, in plastic frame
- Light opening: 410 x 505 mm
- Window frame: black polycarbonate
- Window frames are burglar proof

### 1.2.5.2 TG2



- Double-sided insulated hardened glass, rectangular, in plastic frame
- Light opening: 410 x 1105 mm
- Window frame: black polycarbonate
- Window frames are burglar proof

### 1.2.5.3 TG5



- Double-sided insulated hardened glass, rectangular, in plastic frame
- Light opening: 245 x 555 mm
- Window frame: black polycarbonate
- Window frames are burglar proof

### 1.2.5.4 TG3 - only for passdoor



- Double-sided insulated hardened glass, rectangular, in plastic frame
- Light opening: 260 x 405 mm
- Window frame: black polycarbonate
- Window frames are burglar proof

### 1.2.5.5 TG4 - only for passdoor



- Double-sided insulated hardened glass, rectangular, in plastic frame
- Light opening: 260 x 1005 mm
- Window frame: black polycarbonate
- Window frames are burglar proof

### 1.2.6 Passdoor

For easy access the Crawford FD2050P folding door can be delivered with a passdoor. The passdoor can either be build in a door leaf or in a fixed section. It is also possible to have a door leaf as passdoor in cases where the door has a single leaf or an uneven numbers of leafs on one side.

#### 1.2.6.1 Passdoor in doorleaf

The passdoor is designed with a handle that ensures easy opening and closing of the passdoor. The passdoor is not designed to be an emergency exit, as it has a threshold.

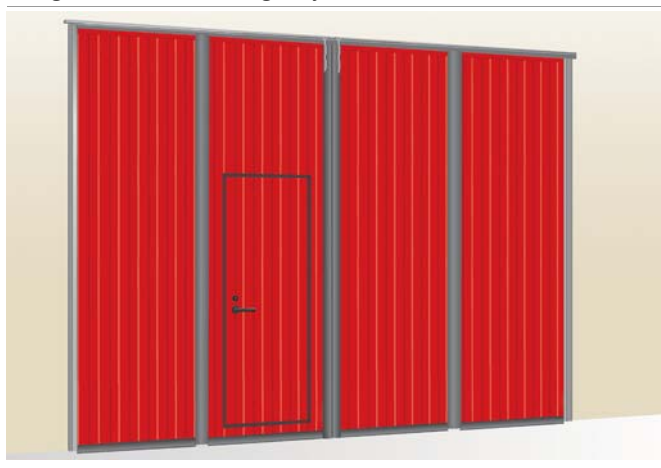

#### Features:

- Always opening outwards, min. 90 degrees opening
- Hinged left or right
- Seals in passdoor frame reduce air permeability.
- Integrated passdoor switch if electrically operated
- All commonly used cylinder locks are available: Euro, Kaba, Abloy, Assa.

#### 1.2.6.2 Door leaf as a passdoor

The passdoor does not have a threshold and is delivered with a cremone lock as standard. The cremone handle ensures easy opening and closing of the passdoor. All commonly used cylinder locks are also available on request.



#### Features:

- No threshold
- Opening direction depends on installation side
- Only manually operated doors
- Cremone lock as standard
- All commonly used cylinder locks are available on request: Euro, Kaba, Abloy, Assa
- Max. recommended door height (DLH): Max. 4 m

### 1.2.7 Fixed sections

Fixed sections can advantageously fill space around new doors that are smaller than the wall opening. Fixed sections are available in top and side sections. Fixed sections are supplied in the same color and construction as the door leaf. A fixed section can be provided with a passdoor for two reasons: Safety and energy cost reduction.

- Safety: Putting a separate passdoor in a fixed section next to the industrial door separates pedestrian and vehicle traffic.
- Energy cost reduction: The opening space for frequent pedestrian traffic is minimized.

## 1.3 Manually operated door

The Crawford FD2050P folding door can be opened and closed by hand, using a solid, easy to grip handle and a cremone lock.

### 1.3.1 Handle

For manual operation the Crawford FD2050P folding door is supplied with a solid, easy to grip handle, installed in combination with an auto lock. The auto lock secures the door in the open position and must be released to close the door.



### 1.3.2 Locks

#### 1.3.2.1 Cremone lock

The standard cremone lock has an inside handle and can lock the door without the use of a key. Optionally an outside cremone handle can be installed on the cremone lock.



#### 1.3.2.2 Cylinder lock

For extra security a cylinder can be installed in combination with the cremone lock.

## 1.4 Electrically operated door

### 1.4.1 Electrical operation

The Crawford FD2050P folding door with a configuration 2+0, 0+2 or 2+2 can be supplied or upgraded with an electrical operating system. The system consists of a mechanical transmission unit with an electrical operator and a control unit. Electrical operation gives access to the full program of Access and Automation functions, that can fulfill many operational needs related to traffic type and frequency, door weight, and temperature control.

### 1.4.2 CDM9 FD Operating system

The CDM9 FD operating system is a combination of the CDM9 FD Operator and a 950 door control system.

#### 1.4.2.1 CDM9 Operator

The CDM9 FD Operator is an electric motor that drives the door via a mechanical transmission unit. It can be retrofitted to an existing Crawford FD2050P folding door if the door is configured for electrical operation. The CDM9 FD Operator is installed directly on the mechanical transmission unit and does not require any special wall reinforcement. The transmission unit is built from anti-corrosive parts to ensure a long life, even in a humid environment.



#### Key features:

- Smooth and silent
- Soft start and stop
- Life time: 300.000 door cycles.

#### 1.4.2.2 950 door control system Door control system

The standard 950 door control system is fully prepared for one or more physical upgrades from the entire range of automation systems. An automation system allows door operation by sensors or remote control.

This control unit contains a 3-digit diagnostics display that allows efficient troubleshooting and displays the number of door cycles completed. Together with the service indicator, this extra feature allows advanced maintenance planning for users where the door is an essential element of internal logistics.

Additional functions such as magnetic loop, photocells, radar and radio are available.



## 1.5 Access and automation

Crawford offers a wide range of functions that allows advanced opening and safety control.

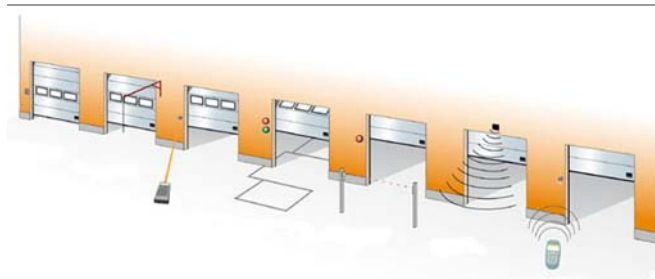

## 1.5.1 Basic control functions

### 1.5.1.1 Interlocking



Developed for climate control or safety; If door A is open, door B cannot be opened. If door B is open, door A cannot be opened. An interlocked door can remember an up-command, if selected via a micro switch.

## 1.5.3 Automatic control functions

### 1.5.3.1 Automatic closing

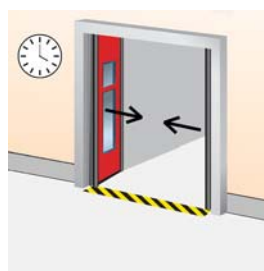

A programmable timer that closes the door after a specified time, counted from either the fully open position and/or from passing through the photocell beam. Adjustable micro switches in control unit.

## 1.5.2 External control functions

### 1.5.2.1 External push button box



An extra control box is installed outside the building or inside close to the door if the main control unit needs to be installed away from the door opening. Installed on the inside or outside wall beside the door.

### 1.5.3.2 Magnetic loop



A sensor in the floor detects a metal object (usually forklift trucks, pallet trucks) and opens the door automatically. This is an ideal solution for frequent vehicle traffic. Installed on the outside, inside or both sides of the door in the floor.

### 1.5.2.2 Pull-rope switch

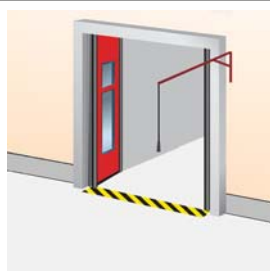

A pull-rope switch above the door opening can be operated from e.g. a forklift truck. Pulling the rope opens a closed door or closes an opened door. Installed on the inside construction above the door.

### 1.5.3.3 Photocell open door

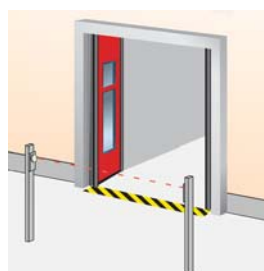

A set of photocells on pillars, on each side of the door. When a person or vehicle passes between the photocells, the beam is interrupted and the door opens. Photocells installed on pillars, away from the door.

### 1.5.2.3 Remote control



A hand-held radio transmitter allows door operation from a vehicle or any position within 50-100 meters from the receiver and aerial at the door. For closing, the door can be provided with a photocell beam. Receiver installed in control unit, antenna installed on the wall beside the door.

### 1.5.3.4 Radar

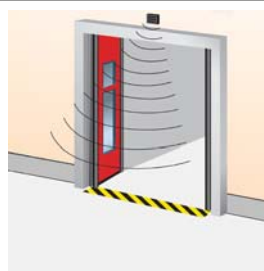

An infrared sensor above the door detects an object (person, vehicle) within a specified distance from the door and opens the door automatically. This is an ideal solution for frequent vehicle or personal traffic. Often combined with automatic closing. Installed on the inside or outside wall above the door.

## 1.5.4 Safety functions

### 1.5.4.1 Safety edge



As a standard, all doors that have the impulse-open function or any form of automated closing, are equipped with a safety edge. The pneumatic sensor in the safety edge seal detects any obstruction between a closing door and reverses the door.

Installed in the safety edge seal.

### 1.5.4.2 Safety photocells 1-channel

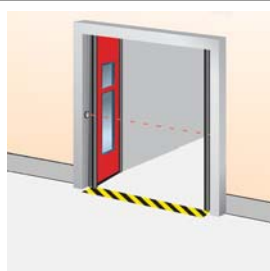

A set of a photocell transmitter and receiver is installed in the door opening. If the photocell beam is interrupted during closing, the door will stop in less than 30mm and reverse to the fully open position.

Installed in the door opening.

### 1.5.4.3 Safety photocells 2-channel

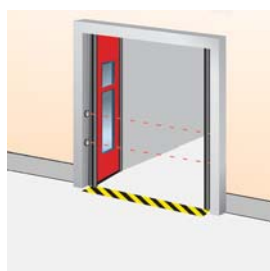

Two sets of photocell transmitter and receiver are installed in the door opening. If one or both photocell beams are interrupted during closing, the door will stop in less than 30mm and reverse to the fully open position.

Installed in the door opening.

### 1.5.4.4 Warning lights - Green

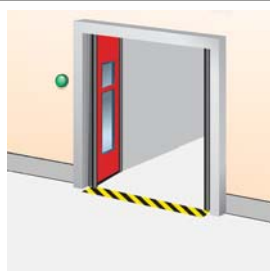

One or two green warning lights indicating the open position of the door by continuous light signal.

Installed on the inside and/or outside wall beside the door.

### 1.5.4.5 Warning lights - Red

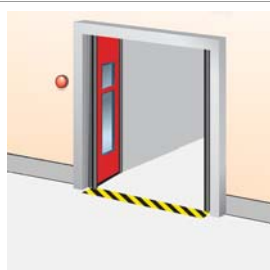

Two red warning lights giving information on the current door behaviour. Flashing light before or during door movement. Optional: Continuous light before and during door movement.

Installed on the inside and outside wall beside the door.

### 1.5.4.6 Traffic lights - Red & Green

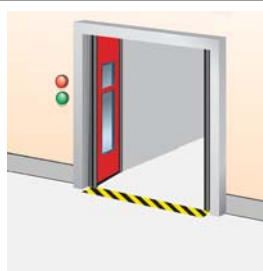

If traffic through a door needs to be directed; two red and two green traffic lights can be installed to indicate traffic direction. From the side where a vehicle is first detected to approach the door, the green traffic light comes on. The opposing side shows a red traffic light. Traffic from this direction must give way to the other. Usually installed in e.g. parking garages.

Installed on the inside and outside wall beside the door.

## 1.5.5 Additional functions

### 1.5.5.1 UPS battery backup



When mains failure cannot be permitted or an increased risk of mains failure is predicted, the UPS battery backup system can be installed to store enough energy for 10 door cycles. Installed on the inside wall beside the door.

### 1.5.5.2 Relay box



A sealed connection box makes it possible to safely connect external high-voltage equipment.

## 1.6 Monitoring systems

As an option on all our products, a Crawford Monitoring System can be installed. This system helps to ensure efficiency and security in daily operations. All doors or docking stations are connected to the Monitoring System's server, which gives the opportunity to supervise, monitor and report a wide variety of aspects in a facility.



### 1.6.1 Saving energy

A monitoring system reduces energy costs and contributes to a better environment. Energy is lost every time a door is open. If a door is open when no truck is at the bay, even more energy is lost.

A Crawford Monitoring System automatically ensures that no door will open unless there is a truck at the bay and even set it to close when there an activity is delayed.

### 1.6.2 Security enhancement

Closing and locking doors is an obvious daily routine. However, checking this manually can be time consuming in a busy facility.

A Crawford Monitoring System can automatically ensure that all doors are closed and locked when they need to be. It can also activate all doors and locks from its remote location, and give a real-time overview of the building's situation.

### 1.6.3 Dock management

A good way to increase throughput and thereby efficiency at a logistics facility is to reduce the time of having no truck – or the wrong truck – at a loading bay.

A Crawford Monitoring System makes visible – in real-time – which bays are occupied or free, and for how long. It makes it possible to reserve bays for docking activities and to inform drivers via SMS. Since it incorporates information from cameras and other inputs (RFID, card readers, etc.), the system stays updated in real-time.

### 1.6.4 Facility management

The Crawford Monitoring System gives a real-time service status for all your door and docking equipment. If an error code occurs, the Crawford service organisation is automatically notified, and will respond quickly. Other maintenance information can easily be integrated, further reducing the overall costs.

## 2. Specifications

### 2.1 Dimensions

#### 2.1.1 Daylight width and daylight height

The standard Crawford FD2050P folding door is delivered in the following size range:

##### Standard door sizes

|       | Daylight width (DLW) | Daylight height (DLH) |
|-------|----------------------|-----------------------|
| Min.: | 1020 mm              | 2000 mm               |
| Max.: | 7590 mm              | 6000 mm               |

Other sizes available on request.

#### 2.1.2 Section sizes





|                  |                |
|------------------|----------------|
| Leaf width (SW): | 553 - 1253 mm* |
| Thickness:       | 50 mm          |

\*The total width of the door is equally divided over the leaves at interval steps of 25 mm.



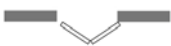

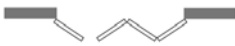
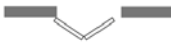
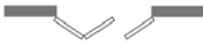
## 2.2 Configurations

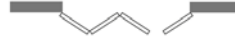
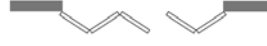
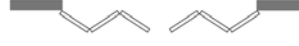
| Configuration* | Dimensions (DLW)  | Manual door | Electric door | Door assembly  |
|----------------|-------------------|-------------|---------------|--|
| 0 + 2          | 1020 mm - 2460 mm | ■           | ■             |   |
| 1 + 2          | 1640 mm - 3750 mm | ■           |               |   |
| 1 + 3          | 2200 mm - 5020 mm | ■           |               |   |
| 2 + 0          | 1020 mm - 2460 mm | ■           | ■             |   |
| 2 + 1          | 1640 mm - 3750 mm | ■           |               |   |
| 2 + 2          | 2200 mm - 5020 mm | ■           | ■             |   |
| 2 + 3          | 2760 mm - 6320 mm | ■           |               |   |
| 3 + 1          | 2200 mm - 5020 mm | ■           |               |   |
| 3 + 2          | 2760 mm - 6320 mm | ■           |               |   |
| 3 + 3          | 3393 mm - 7590 mm | ■           |               |  |

■ Available

\* Other configurations available on request

## 2.3 Passdoor

### 2.3.1 Passdoor in doorleaf

#### Passdoor size limitations

| Type         | Passdoor width [mm] | Min leaf width [mm] | Windows     |
|--------------|---------------------|---------------------|-------------|
| Passdoor 600 | 595                 | 878                 | TG3/TG4/TG5 |
| Passdoor 800 | 820                 | 1103                | TG3/TG4/TG5 |

#### Specifications

Lock: Depends on market

Treshold height: 115 mm incl. bottom seal

This passdoor is only available in the second door leaf from the wall.

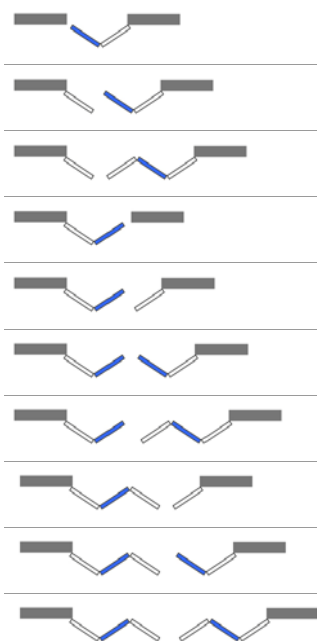

## 2.3.2 Doorleaf as a passdoor

### Passdoor size limitations

|                                    |           |
|------------------------------------|-----------|
| Minimum height                     | 2000 mm   |
| Maximum daylight height            | 3300 mm   |
| Max. recommended door height (DLH) | Max. 4 m. |

### Specifications

|                  |  |
|------------------|--|
| Treshold height: | None   |
| Handle/lock      | Standard: Cremone lock<br>Optional: Lock with roller latch |
| Lock             | Depends on market  |

This passdoor is only available as the first or third door leaf from the wall.

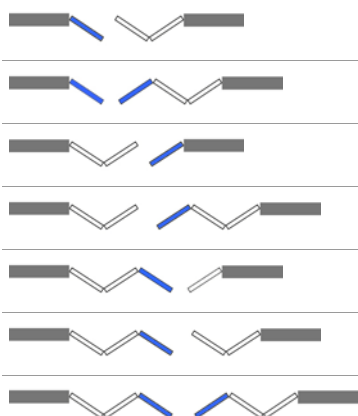

## 2.4 Door operation

### 2.4.1 Selection guidelines for operation type

| Door size m <sup>2</sup> | Openings / day |          |           |         |
|--------------------------|----------------|----------|-----------|---------|
|                          | 1-5/day        | 5-10/day | 10-15/day | >25/day |
| 0 - 10                   | □ / ■          | □ / ■    | ■ / ■     | ■ / ■   |
| 10 - 20                  | □ / ■          | ■        | ■ / ■     | ■ / ■   |
| > 20 - 42                | ■              | ■        | ■ / ■     | ■ / ■   |
| > 42*                    | □              | □        | □         | □       |

- Manual operation
- Electrical operation
- Automated operation

## 2.4.2 950 door control system functions

| Functions             | 950 FD  |
|-----------------------|---|
|                       |  |
| Open (by impulse)     | <input checked="" type="checkbox"/>   |
| Stop                  | <input checked="" type="checkbox"/>   |
| Close (by impulse)    | <input checked="" type="checkbox"/>   |
| Safety edge           | <input checked="" type="checkbox"/>   |
| Open function         | <input checked="" type="checkbox"/>   |
| One button function   | <input checked="" type="checkbox"/>   |
| Display (diagnostics) | <input checked="" type="checkbox"/>   |
| Service indicator     | <input checked="" type="checkbox"/>   |

## 2.4.3 950 door control system - Selection guidelines for automation

The "Automation D-kits" are packages of common combinations. These kits can also be supplemented by "additions to D-kits".

| Automation D-kits               | D1                                  | D2                                  | D3                                  | D4                                  | D5                                  | D6                                  | D7                                  |
|---------------------------------|-------------------------------------|-------------------------------------|-------------------------------------|-------------------------------------|-------------------------------------|-------------------------------------|-------------------------------------|
| Interlocking                    | <input checked="" type="checkbox"/> | <input checked="" type="checkbox"/> | <input checked="" type="checkbox"/> | <input checked="" type="checkbox"/> | <input checked="" type="checkbox"/> | <input checked="" type="checkbox"/> | <input checked="" type="checkbox"/> |
| Magnetic loop                   |                                     | <input checked="" type="checkbox"/> |                                     | <input checked="" type="checkbox"/> |                                     | <input checked="" type="checkbox"/> |                                     |
| Traffic lights -<br>Green + Red |                                     |                                     |                                     |                                     | <input checked="" type="checkbox"/> | <input checked="" type="checkbox"/> |                                     |
| Warning lights - Red            | <input checked="" type="checkbox"/> |                                     |                                     | <input checked="" type="checkbox"/> |                                     |                                     |                                     |
| <b>Additions to D-kits</b>      |                                     |                                     |                                     |                                     |                                     |                                     |                                     |
| Warning lights - Green          |                                     |                                     | <input type="checkbox"/>            |                                     |                                     |                                     |                                     |
| Relay box                       | <input type="checkbox"/>            | <input type="checkbox"/>            | <input type="checkbox"/>            | <input type="checkbox"/>            | <input type="checkbox"/>            | <input type="checkbox"/>            | <input type="checkbox"/>            |
| Radar                           | <input type="checkbox"/>            | <input type="checkbox"/>            | <input type="checkbox"/>            | <input type="checkbox"/>            | <input type="checkbox"/>            | <input type="checkbox"/>            | <input type="checkbox"/>            |

Standard

Option / Available

The following options can be individually selected to add functionality to the control unit.

|                           |        |
|---------------------------|--------|
| <b>Functions optional</b> | 950 FD |
|---------------------------|--------|



**Complete kits**

|                   |                          |
|-------------------|--------------------------|
| Automation D-kits | <input type="checkbox"/> |
|-------------------|--------------------------|

**Basic control functions**

|              |                          |
|--------------|--------------------------|
| Interlocking | <input type="checkbox"/> |
|--------------|--------------------------|

**External control functions**

|                          |                          |
|--------------------------|--------------------------|
| External push-button box | <input type="checkbox"/> |
|--------------------------|--------------------------|

|                  |                          |
|------------------|--------------------------|
| Pull-rope switch | <input type="checkbox"/> |
|------------------|--------------------------|

|                                   |                          |
|-----------------------------------|--------------------------|
| Remote control<br>open/stop/close | <input type="checkbox"/> |
|-----------------------------------|--------------------------|

|                                     |                          |
|-------------------------------------|--------------------------|
| Remote control<br>1-button function | <input type="checkbox"/> |
|-------------------------------------|--------------------------|

**Automatic control functions**

|                   |                          |
|-------------------|--------------------------|
| Automatic closing | <input type="checkbox"/> |
|-------------------|--------------------------|

|                     |                          |
|---------------------|--------------------------|
| Photocell open door | <input type="checkbox"/> |
|---------------------|--------------------------|

**Safety functions**

|                       |                          |
|-----------------------|--------------------------|
| Safety photocells 1-2 | <input type="checkbox"/> |
|-----------------------|--------------------------|

**Additional functions**

|                    |                          |
|--------------------|--------------------------|
| UPS Battery backup | <input type="checkbox"/> |
|--------------------|--------------------------|

|           |                          |
|-----------|--------------------------|
| Relay box | <input type="checkbox"/> |
|-----------|--------------------------|

- Standard
- Option / Available

## 3. CEN Performance

### 3.1 Lifetime expectation

300.000 door cycles or 20 years (in a normal industrial environment and with the recommended yearly service check)

### 3.2 Resistance to windload

| EN12424                   | Manually operated door | Electrically operated door |
|---------------------------|------------------------|----------------------------|
| DLW 7590 mm x DLH 6000 mm | Class 2                | -                          |
| DLW 5000 mm x DLH 6000 mm | Class 2                | Class 3                    |
| DLW 3500 mm x DLH 3000 mm | Class 3                | Class 5                    |

### 3.3 Resistance to water penetration

| EN12425     | Without passdoor |
|-------------|------------------|
| Test result | Class 3          |

### 3.4 Air permeability

| EN12426     | Without passdoor |
|-------------|------------------|
| Test result | Class 2          |

### 3.5 Thermal transmittance

| EN12428               | Double Acrylic/Glass    |
|-----------------------|-------------------------|
| Thermal transmittance | 1,7 W/m <sup>2</sup> K* |

\* These values are calculated values for a complete, installed, door of 4000 x 4000 mm and have to be confirmed by an official test.

### 3.6 Operating forces and safe openings

| EN12453 & EN12604 | Crushing force N                              | Crushing force N                  | Crushing force N                             |
|-------------------|---|-----------------------------------|--|
| Opening gap mm    | 200 mm from lateral border right from outside | In the middle of the door opening | 200 mm from lateral border left from outside |
| 50 N              | passed  | passed                            | passed                                       |
| 300 N             | passed  | passed                            | passed                                       |

The crushing force is the force needed for the safety edge to be activated. The maximum force allowed, according to EN12453 safety in use of power operated doors, is 400 N within a period of time of 0.75 s.

## 4. Building and space requirements

### 4.1 Building preparations

#### 4.1.1 Installation preparations

The Crawford FD2050P folding door is shipped in parts and installed on-site. All necessary installation material is included. For every building type Crawford offers specific installation kits to install the door in the building facade.

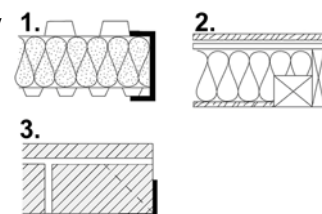

- 1) Steel
- 2) Wood
- 3) Brick & Concrete

#### 4.1.2 Electrical preparations

The manually operated door needs no electrical supply.

For an electrically operated door, the following environment criteria and electrical supplies are required for the operator to function properly:

|  | CDM9 FD                             |
|--|-------------------------------------|
| <b>Voltage supply:</b><br>(+/- 10%)              | 230V AC 1-phase 50/60Hz             |
| <b>Power supply:</b>                             | 0,5 kW                              |
| <b>Degree of protection:</b>                     | IP55, excl. connector IP 44         |
| <b>Max. allowed total weight of door leaves:</b> | 750 kg                              |
| <b>Working temperature range:</b>                | -20 °C to +60 °C*                   |
| <b>Operating factor:</b>                         | ED = 30%<br>S3 10 min. intermittent |
| <b>Installation preparations:</b>                | -                                   |

\*) Normal opening speed in temperatures down to -8°C. In the temperature range -8 °C to -20 °C the opening speed is reduced during the first cycle in a two-hour period to prolong the operator's lifetime. An optional heating element is available for a working range down to -30 °C

## 4.2 Space requirements

### 4.2.1 Dimension terminology

|     |                        |   |
|-----|------------------------|---|
| DLW | = Daylight Width       | The width of the clear opening.               |
| DLH | = Daylight Height      | The height of the clear opening.              |
| OH  | = Headroom             | The space required above the daylight height. |
| SL  | = Side space Left      | The space required beside the daylight width. |
| SR  | = Side space Right     | The space required beside the daylight width. |
| D   | = Depth                | The space required to move the door leaves.   |
| SW  | = Section / leaf width | The width of a single door leaf.              |

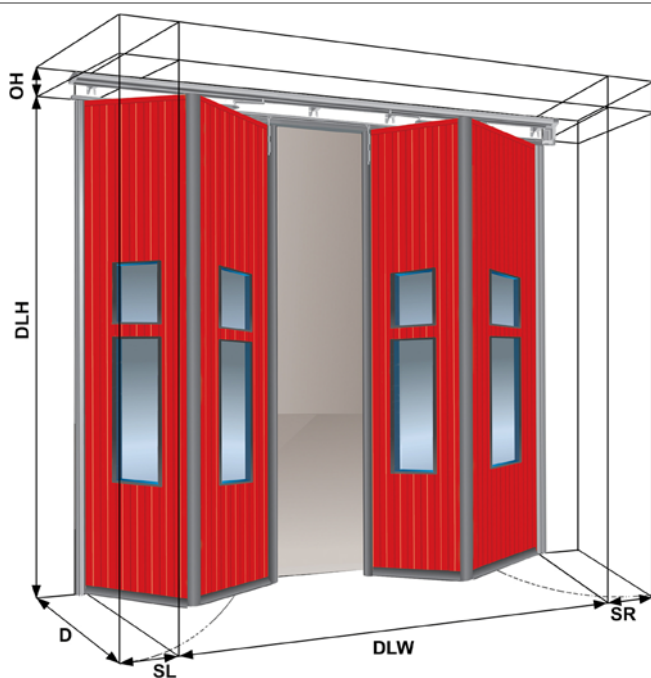

### 4.2.2 Space requirements manual doors

#### Configuration

|     | SL      | SR      | OH  |
|-----|---------|---------|-----|
| 0+2 | 175     | 185-285 | 150 |
| 2+2 | 185-285 | 185-285 | 150 |
| 2+0 | 185-285 | 175     | 150 |

\* Dimensions in mm.



#### 4.2.3 Space requirements electrically operated doors

| <b>No plastic cover on operator*</b> |                               |           |           |                                |           |           |                                 |           |           |
|--------------------------------------|-------------------------------|-----------|-----------|--------------------------------|-----------|-----------|---------------------------------|-----------|-----------|
| <b>Configuration</b>                 | <b>Operator position left</b> |           |           | <b>Operator position right</b> |           |           | <b>Operator position center</b> |           |           |
|                                      | <b>SL</b>                     | <b>SR</b> | <b>OH</b> | <b>SL</b>                      | <b>SR</b> | <b>OH</b> | <b>SL</b>                       | <b>SR</b> | <b>OH</b> |
| 0+2                                  | 175                           | 350       | 235       | 175                            | 550       | 235       | N.A.                            | N.A.      | N.A.      |
| 2+2                                  | 490                           | 350       | 235       | 350                            | 550       | 235       | 350                             | 350       | 375       |
| 2+0                                  | 490                           | 175       | 235       | 350                            | 215       | 235       | N.A.                            | N.A.      | N.A.      |

\* Dimensions in mm.

| <b>With plastic cover on operator*</b> |                               |           |           |                                |           |           |                                 |           |           |
|--|-------------------------------|-----------|-----------|--------------------------------|-----------|-----------|---------------------------------|-----------|-----------|
| <b>Configuration</b>                   | <b>Operator position left</b> |           |           | <b>Operator position right</b> |           |           | <b>Operator position center</b> |           |           |
|  | <b>SL</b>                     | <b>SR</b> | <b>OH</b> | <b>SL</b>                      | <b>SR</b> | <b>OH</b> | <b>SL</b>                       | <b>SR</b> | <b>OH</b> |
| 0+2                                    | 175                           | 350       | 270       | 175                            | 57        | 270       | N.A.                            | N.A.      | N.A.      |
| 2+2                                    | 510                           | 350       | 270       | 35                             | 57        | 270       | 350                             | 350       | 395       |
| 2+0                                    | 510                           | 175       | 270       | 350                            | 240       | 270       | N.A.                            | N.A.      | N.A.      |

\* Dimensions in mm.

#### 4.2.4 Depth

The minimal required depth is the width of a door leaf (SW 553-1253mm) + 180 mm

# 5. Service

## Preventive Maintenance Program and Modernization Services

As your entrances are part of your business flow, there's every reason to keep them working well. ASSA ABLOY Entrance Systems offers you a maintenance and modernization expertise to rely on. Our Maintenance Programs and Modernization Services are backed by a extensive expertise for all types of industrial door and docking systems, independent of brand. At your disposal is a team of dedicated expert technicians, proven through decades of maintenance, service and satisfied customers.

### Preventive Maintenance Programs

Minimizing lost time, lost energy and unexpected hassle is our team's constant objective. Our service organization can support you 24/7 in maintaining all industrial door and docking systems, independent of brand. If you want to be one step ahead of break-downs, explore our portfolio of Pro-Active Care plans. Naturally, we also offer entrance upgrades to suit your specific wishes and business needs.

### Pro-Active Care - Maintenance plans to fit your business

Regular maintenance can extend the lifetime of your equipment and help prevent unexpected problems. Our technician arrives on-site equipped with the knowledge and tools to service all automatic entrances, independent of brand.

- **Pro-Active Bronze**

The base on which all Pro-Active Plans are built provides the security of knowing that your equipment is regularly inspected and certified for safety, as well as performing optimally. It includes a number of planned on-site visits depending on your needs. Any unplanned service calls required during the term of the contract (including labor, travel and parts) are billed at special Pro-Active Care prices.

- **Pro-Active Silver**

This plan provides all the benefits of Pro-Active Bronze with the added advantage of labor and travel being included for service calls during regular business hours. The only additional charge would be for any parts that may be needed throughout the term of the contract.

- **Pro-Active Gold**

This plan provides the ultimate protection for your automatic entrance investment. It includes all the benefits of Pro-Active Silver, plus replacement of any parts required during an unplanned repair or planned maintenance visit. Pro-Active Gold is an excellent way to budget your automatic door expenses annually.

- **Pro-Active Tailor-Flex**

Our most flexible maintenance and service offering. The Pro-Active Care plan is designed by you, our customer. The plan allows you to balance your maintenance expenses against your real-world budget and presents the option to add or delete a number of maintenance elements to suit your budget goals, while meeting your overall performance and safety needs.

### Modernization

Your entrances are a long-term investment, from which you always want the best. Products develop over time, so do regulations and your business. Let us help you increase energy savings and meet today's standards. We provide advice and modernization kits for outdated installations, ensuring your investment meet requirements and performs optimally for many more years to come.

| Re-Active Service |             | Pro-Active Care   |                   |                 |                        |   |
|-------------------|-------------|-------------------|-------------------|-----------------|------------------------|---|
|                   |             | Pro-Active Bronze | Pro-Active Silver | Pro-Active Gold | Pro-Active Tailor Flex |   |
|                   |             | ○                 | ○                 | ○               | ●                      | Other customized requests such as Response Time, Performance InfoPack and Advanced User Training                    |
|                   |             | ○                 | ○                 | ●               | ○                      | Replacement of worn parts according to preventive Consumable Exchange Program                                       |
|                   |             | ○                 | ○                 | ●               | ○                      | Replacement of spare parts on breakdowns  |
|                   |             | ○                 | ●                 | ●               | ○                      | Travel and labor for additional call-out visits   |
|                   |             | ●                 | ●                 | ●               | ●                      | Preventive maintenance visits 1-4 times per year  |
|                   |             | ●                 | ●                 | ●               | ●                      | Travel and labor for preventive maintenance visits  |
|                   |             | ●                 | ●                 | ●               | ●                      | Response time and priority on call-outs <24h  |
|                   |             | ●                 | ●                 | ●               | ●                      | Preventive planned maintenance that meets the most demanding standards in the market                                |
|                   | ●           | ●                 | ●                 | ●               | ●                      | Safety and quality checks according to applicable regulations and norms. Documentation of test results provided     |
| ●                 | ●           | ●                 | ●                 | ●               | ●                      | Documentation of equipment status, assessment and service provided, all generated on site                           |
| ●                 | ●           | ●                 | ●                 | ●               | ●                      | Highly trained professional technicians with extensive knowledge, state-of-the-art tools and the right spare parts* |
| ●                 | ●           | ●                 | ●                 | ●               | ●                      | Dedicated Professional Customer Care Hotline  |
| Corrective        | SafetyCheck | Pro-Active Bronze | Pro-Active Silver | Pro-Active Gold | Pro-Active Tailor Flex |   |

● = Included as standard  
○ = Available at special prices

\* Well-stocked service vehicles with genuine and new spare parts

# Index

## Numerics

|   |    |
|---|----|
| 950 door control system - Selection guidelines for automation ..... | 20 |
| 950 door control system Door control system .....                   | 12 |
| 950 door control system functions                                   | 20 |

## A

|                                   |    |
|-----------------------------------|----|
| Access and automation .....       | 12 |
| Additional functions .....        | 14 |
| Air permeability .....            | 22 |
| Automatic closing .....           | 13 |
| Automatic control functions ..... | 13 |

## B

|                                       |    |
|---------------------------------------|----|
| Basic control functions .....         | 13 |
| Bottom seal .....                     | 8  |
| Building and space requirements ..... | 23 |
| Building preparations .....           | 23 |

## C

|                                       |    |
|---------------------------------------|----|
| CDM9 FD Operating system .....        | 12 |
| CDM9 Operator .....                   | 12 |
| CEN Performance .....                 | 22 |
| Colours .....                         | 7  |
| Configurations .....                  | 17 |
| Construction .....                    | 7  |
| Copyright and Disclaimer Notice ..... | 2  |
| Cremona lock .....                    | 11 |
| Cylinder lock .....                   | 11 |

## D

|                                    |    |
|------------------------------------|----|
| Daylight width and daylight height | 16 |
| Depth .....                        | 25 |
| Description .....                  | 6  |
| Dimension terminology .....        | 24 |
| Dimensions .....                   | 16 |
| Dock management .....              | 15 |
| Door leaf as a passdoor .....      | 10 |
| Door leaves .....                  | 7  |
| Door operation .....               | 19 |
| Doorleaf as a passdoor .....       | 19 |

## E

|                                  |    |
|----------------------------------|----|
| Electrical operation .....       | 12 |
| Electrical preparations .....    | 23 |
| Electrically operated door ..... | 12 |
| External control functions ..... | 13 |
| External push button box .....   | 13 |

## F

|                           |    |
|---------------------------|----|
| Facility management ..... | 15 |
| Features .....            | 3  |
| Fixed sections .....      | 10 |

## G

|               |   |
|---------------|---|
| General ..... | 6 |
|---------------|---|

## H

|              |    |
|--------------|----|
| Handle ..... | 11 |
|--------------|----|

## I

|                                 |    |
|---------------------------------|----|
| Installation preparations ..... | 23 |
| Interlocking .....              | 13 |

## L

|                            |    |
|----------------------------|----|
| Lifetime expectation ..... | 22 |
| Locks .....                | 11 |

## M

|                              |    |
|------------------------------|----|
| Magnetic loop .....          | 13 |
| Manually operated door ..... | 11 |
| Material .....               | 7  |
| Monitoring systems .....     | 15 |

## O

|                                    |    |
|------------------------------------|----|
| Operating forces and safe openings | 22 |
| Optional colours .....             | 7  |
| Options .....                      | 6  |

## P

|                            |        |
|----------------------------|--------|
| Passdoor .....             | 10, 18 |
| Passdoor in doorleaf ..... | 10, 18 |
| Performance .....          | 3      |
| Photocell open door .....  | 13     |
| Pull-rope switch .....     | 13     |

## R

|                                       |    |
|---------------------------------------|----|
| Radar .....                           | 13 |
| Relay box .....                       | 14 |
| Remote control .....                  | 13 |
| Resistance to water penetration ..... | 22 |
| Resistance to windload .....          | 22 |

## S

|  |    |
|--|----|
| Safety edge .....                                    | 14 |
| Safety edge seal .....                               | 8  |
| Safety functions .....                               | 14 |
| Safety photocells 1-channel .....                    | 14 |
| Safety photocells 2-channel .....                    | 14 |
| Saving energy .....                                  | 15 |
| Seal between hinged leaves .....                     | 8  |
| Seals .....  | 8  |
| Section sizes .....                                  | 16 |
| Security enhancement .....                           | 15 |
| Selection guidelines for operation type 19           |    |
| Service .....  | 26 |
| Side cover .....                                     | 8  |
| Side seal .....                                      | 8  |
| Space requirements .....                             | 24 |
| Space requirements electrically operated doors ..... | 25 |
| Space requirements manual doors                      | 24 |
| Specifications .....                                 | 16 |
| Standard .....                                       | 6  |
| Standard colours .....                               | 7  |

## T

|                                    |    |
|------------------------------------|----|
| Technical facts .....              | 3  |
| TG1 .....                          | 9  |
| TG2 .....                          | 9  |
| TG3 - only for passdoor .....      | 9  |
| TG4 - only for passdoor .....      | 9  |
| TG5 .....                          | 9  |
| Thermal transmittance .....        | 22 |
| Top seal .....                     | 8  |
| Traffic lights - Red & Green ..... | 14 |

## U

|                          |    |
|--------------------------|----|
| UPS battery backup ..... | 14 |
|--------------------------|----|

W

|                              |    |
|------------------------------|----|
| Warning lights - Green ..... | 14 |
| Warning lights - Red .....   | 14 |
| Windows .....                | 9  |

ASSA ABLOY Entrance Systems is a leading supplier of entrance automation solutions for efficient flow of goods and people. With our globally recognized product brands Besam, Crawford, Megadoor and Albany, we offer products and services dedicated to satisfying end-user needs for safe, secure, convenient and sustainable operations.  
ASSA ABLOY Entrance Systems is a division within ASSA ABLOY.

**ASSA ABLOY**

[assaabloyentrance.com](http://assaabloyentrance.com)

Q3.0 - 2014

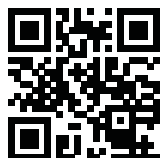

ASSA ABLOY Entrance Systems

[assaabloyentrance.com](http://assaabloyentrance.com)